

Jasco Z-Wave In-wall Smart Fan Control

JASCO®

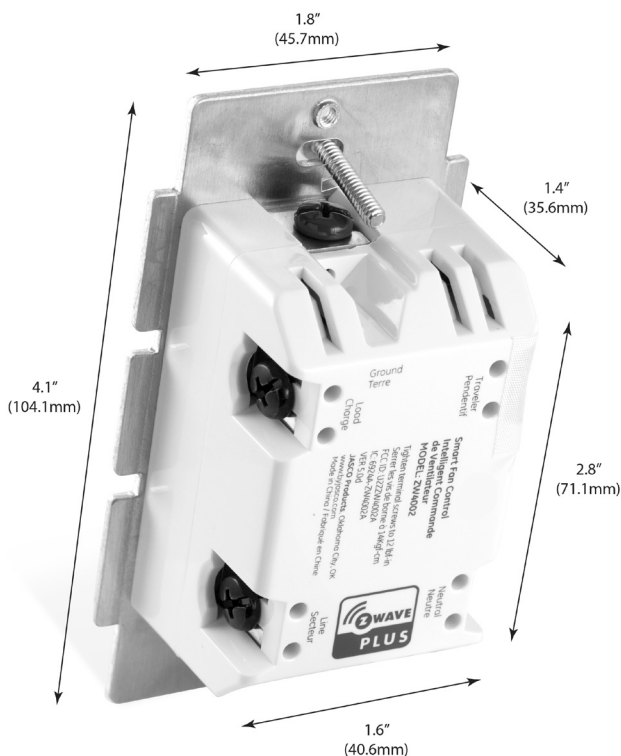
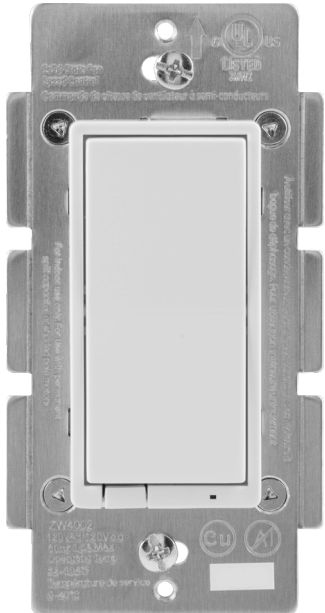

Specifications

Power: 120VAC, 60Hz **Signal Frequency:** 908.4/916

Maximum Fan Motor Load: 2.5A

Range: Up to 150 feet from controller or closest Z-Wave device

Operating Temperature: 32-104° F (0-40° C)

Warranty: 5-year limited product warranty

Requires neutral wire. Switch must be mounted indoors

Control fan motor only, not intended for lighting control. No more than two fans

Design Features

- Remotely monitor with any mobile device*
- May be used in single pole installation or with up to four Jasco model 46560 Add-on switches in 3, 4, 5 or 6-way wiring configurations
- Turn ON/OFF and control speed level of the connected Ceiling fan manually or via Z-Wave remote control (On/Off, High, Medium, Low)
- Can be Included in multiple Groups and Scenes
- Supports Advanced Configuration; LED status, Invert switch (if unit is installed upside down)
- Screw Terminal installation; requires wiring connections for Line (Hot), Load, Neutral and Ground. Traveler wire required for multi pole installation
- Use a standard size wall plate for single gang installations (wallplate not included)
- Interchangeable Paddle switch: White & light almond paddle included in package
- LED can be enabled/disabled manually
- Inline traveler circuit protection

Z-Wave Plus Features

- Backward compatible with all generations of Z-Wave devices
- Improved battery life and up to 50% more wireless range
- 250% faster processor
- 400% more memory
- 50% more energy efficient
- Supports wireless upgrades to future-proof your home

White/light almond paddles included

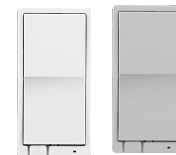

* Requires Z-Wave hub or controller, functions may vary depending on brand.

Single Location Wiring

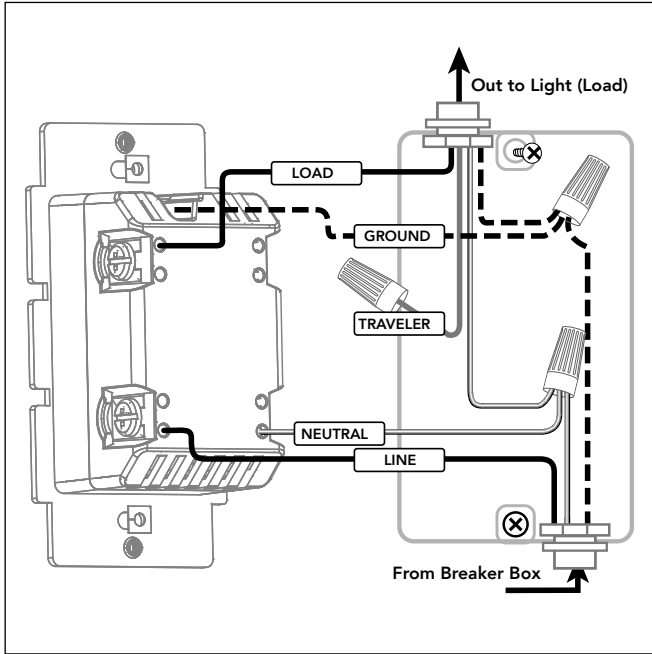

Space-Saving Screw Terminals

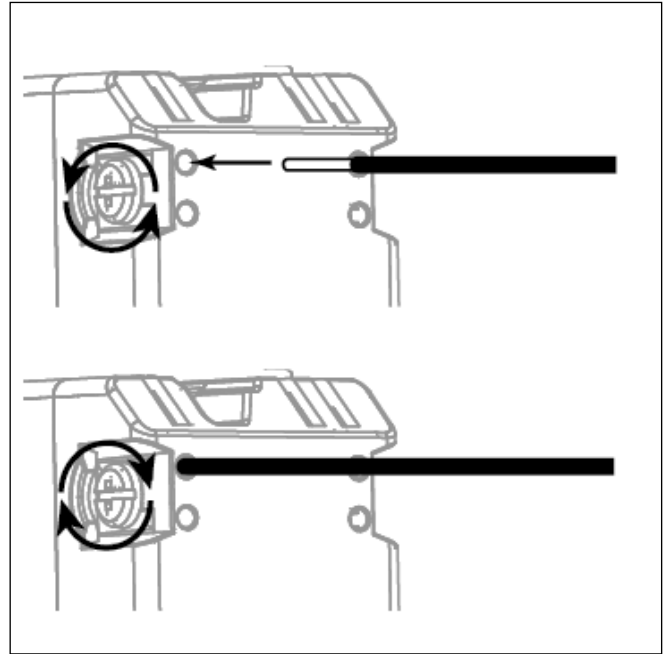

Multi-Location Wiring

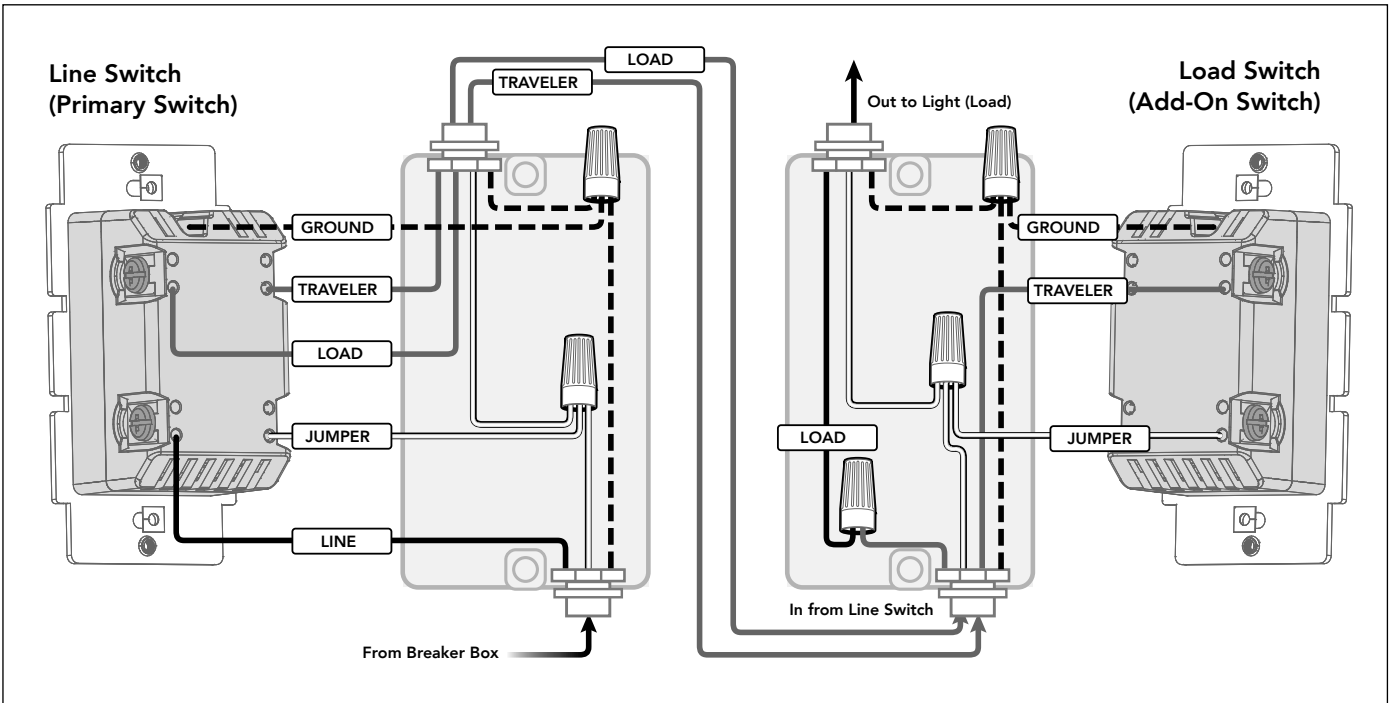

Installation Recommendations:

- Insert wires into holes, do not wrap wires around screws. Do not remove screws.
- Devices require a 1-gang U.S. wall box. 3½ in deep recommended, 2¼ in deep minimum.
- Indoor use only
- Visit <http://www.ezwave.com/hubs/> for hub compatibility
- Wallplates sold separately
- Trilingual Instruction manual – (English, French, Spanish)

Device Configuration

Adding your device to a Z-Wave network

Once the hub is ready to add your smart fan control, press and release the top or bottom button on the smart fan control to add it in the network.

To remove and reset the device

Once the controller is ready to remove your device, press and release the top or bottom button on the smart fan control to remove it from the network.

To return to factory defaults

Quickly press the ON button 3 times, then press the OFF button 3 times. The LED will flash ON/OFF 5 times when completed successfully

Certifications & Compliances



Compliances, specifications and availability are subject to change without notice

Distributed by Jasco Products Company LLC
10 E. Memorial Rd., Oklahoma City, OK

Questions? Contact our U.S.-based Consumer Care at 1-800-654-8483 between 7AM-8PM, M-F, Central Time.

©Jasco 2020

Related Products - Z-Wave Smart Controls



46560
Add-On
Switch



46564
In-Wall
Smart Dimmer



24770
In-Wall Smart
Motion Switch



26932
In-Wall Smart
Motion Dimmer



55257
In-Wall
Smart Outlet
CAV

Additional Paddle Colors



13940
Black Paddle



13943
Brown Paddle



13945
Ivory Paddle